

# **Mini Carpet Extractor** (4 Gallon)

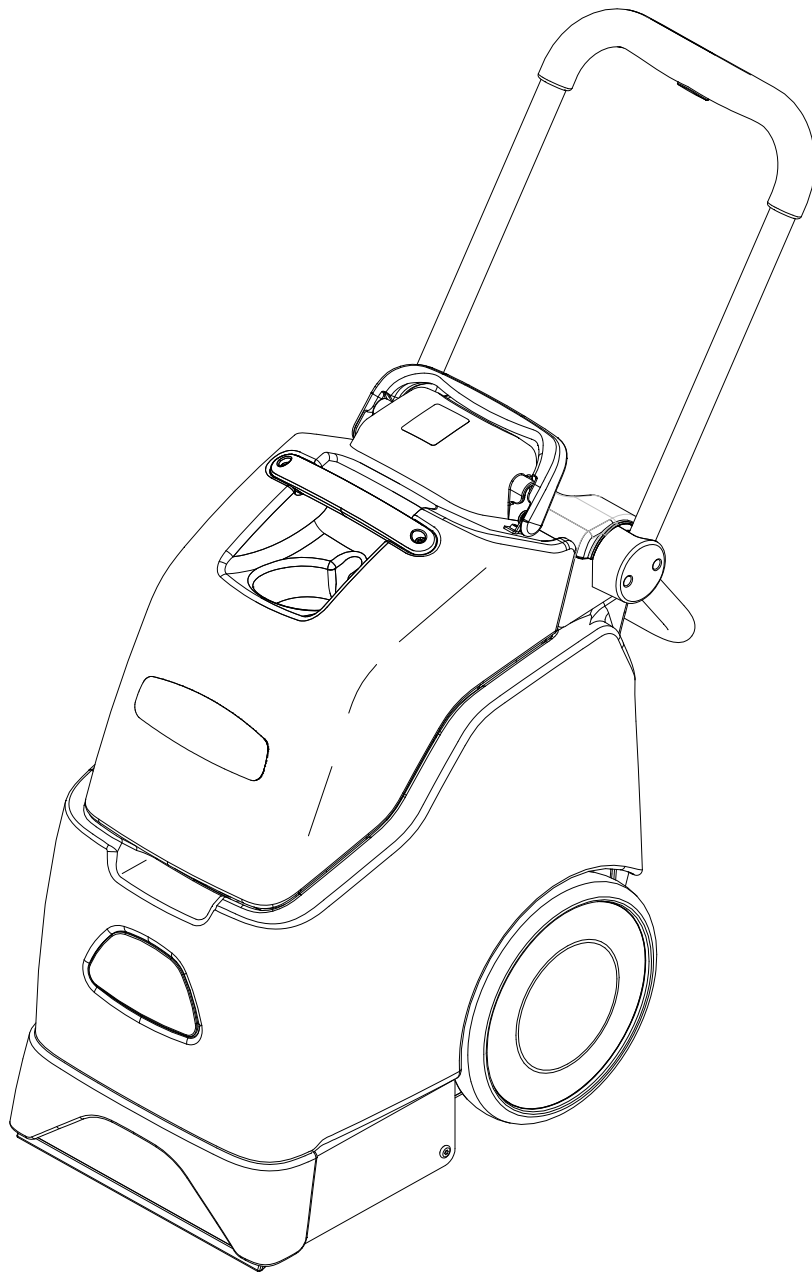

Operating instructions (ENG)

**MODELS:**                    **MPRO**  
   **10080390**

**MPROEU**  
**10080400**

**MPROGB**  
**10080410**

**MPROAU**  
**10080420**

Read these instructions before using the machine.



Model: \_\_\_\_\_

Date of Purchase: \_\_\_\_\_

Serial Number: \_\_\_\_\_

Dealer: \_\_\_\_\_

Address: \_\_\_\_\_

Phone Number: \_\_\_\_\_

Sales Representative: \_\_\_\_\_

### **OVERVIEW**

The carpet extractor is a mains powered, portable extractor intended for commercial use. The appliance sprays a cleaning solution onto the carpet, agitates the wet carpet, and then extracts the soiled solution back into the unit's recovery tank. The appliance can be fitted with an accessory tool for cleaning upholstery and stairs.

**Machine Data Log & Overview** .....2  
**Table of contents** .....3  
**How to Use This Manual** .....4

*Safety*

IMPORTANT SAFETY INSTRUCTIONS.....5  
HAZARD INTENSITY LEVEL.....6  
GROUNDING INSTRUCTIONS.....7  
Safety Label Location.....8

*Operation*

Inspection.....9  
Chemicals.....9  
Controls & Components.....10  
Filling The Solution Tank.....11  
Operating the Machine.....12  
Operating Machine With Accessory Tools.....12

*Maintenance*

Protect From Freezing.....13  
Daily Regular Maintenance.....13  
Periodic Maintenance.....13  
Maintenance Instructions.....14  
Brush Assembly.....14  
Spray Jet.....14  
Brush Motor Removal.....15  
Pump Removal.....15  
Vacuum Motor Removal.....16  
Troubleshooting.....17

*PARTS*

Brush Deck.....20  
Control Panel.....22  
Decal.....24  
Frame & Wheels.....26  
Handle.....28  
Solution.....30  
Tank & Dome.....34  
Vacuum.....36  
Wiring Diagram-Control Panel 115V.....38  
Wiring Diagram-Vacuum, Brush  
Motor & Pump115V.....40  
Wiring Diagram-Control Panel 230V.....42  
Wiring Diagram-Vacuum, Brush  
Motor & Pump 230V.....44  
Hose Diagram.....46  
Spare Parts.....47  
Accessories.....47  
Serial Numbers.....48

## How to Use This Manual

This manual contains the following sections:

- HOW TO USE THIS MANUAL
- SAFETY
- OPERATIONS
- MAINTENANCE
- PARTS LIST

The HOW TO USE THIS MANUAL section will tell you how to find important information for ordering correct repair parts.

Parts may be ordered from authorized dealers. When placing an order for parts, the machine model and machine serial number are important. Refer to the MACHINE DATA box which is filled out during the installation of your machine. The MACHINE DATA box is located on the inside of the front cover of this manual.

The model and serial number of your machine is located on the lower back panel.

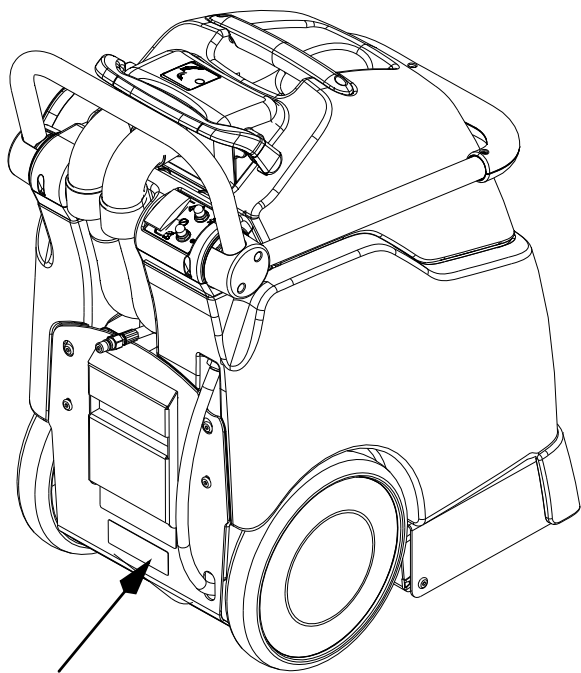

The SAFETY section contains important information regarding hazardous or unsafe practices of the machine. Levels of hazards are identified that could result in product damage, personal injury, or severe injury resulting in death.

The OPERATIONS section is to familiarize the operator with the operation and function of the machine.

The MAINTENANCE section contains preventive maintenance to keep the machine and its components in good working condition. They are listed in this general order:

- Periodic
- Daily/Regular
- Troubleshooting

The PARTS LIST section contains assembled parts illustrations and corresponding parts list. The parts lists include a number of columns of information:

- **REF** - column refers to the reference number on the parts illustration.
- **PART NO.** - column lists the part number for the part.
- **PRV NO.** - Reference number.
- **QTY** - column lists the quantity of the part used in that area of the machine.
- **DESCRIPTION** - column is a brief description of the part.
- **SERIAL NO. FROM** - column indicates the first machine the part number is applicable to. When the machine design has changed, this column will indicate serial number of applicable machine. The main illustration shows the most current design of the machine. The boxed illustrations show older designs. If column has an asterisk (\*), call manufacturer for serial number.
- **NOTES** - column for information not noted by the other columns.

**NOTE:** If a service or option kit is installed on your machine, be sure to keep the **KIT INSTRUCTIONS** which came with the kit. It contains replacement parts numbers needed for ordering future parts.

**NOTE:** The manual part number is located on the lower left corner of the front cover.

## IMPORTANT SAFETY INSTRUCTIONS

When using an electrical appliance, basic precaution must always be followed, including the following:

**READ ALL INSTRUCTIONS BEFORE USING THIS MACHINE.**

**This machine is for commercial use.**

**⚠ WARNING:** To reduce the risk of fire, electric shock, or injury:

Connect to a properly grounded outlet. See Grounding Instructions.

Do not leave the machine unattended. Unplug machine from outlet when not in use and before maintenance or service.

Use only indoors. Do not use outdoors or expose to rain.

Do not allow machine to be used as a toy. Close attention is necessary when used by or near children.

Use only as described in this manual. Use only manufacturer's recommended components and attachments.

Do not use damaged electrical cord or plug. Follow all instructions in this manual concerning grounding the machine. If the machine is not working properly, has been dropped, damaged, left outdoors, or dropped into water, return it to an authorized service center.

Do not pull or carry machine by electrical cord, use as a handle, close a door on cord, or pull cord around sharp edges or corners.

Do not run machine over cord. Keep cord away from heated surfaces.

Do not unplug machine by pulling on cord. To unplug, grasp the electrical plug, not the electrical cord.

Do not handle the electrical plug or machine with wet hands.

Do not operate the machine with any openings blocked. Keep openings free of debris that may reduce airflow.

This machine is intended for cleaning carpet only.

Do not vacuum anything that is burning or smoking, such as cigarettes, matches, or hot ashes.

This machine is not suitable for picking up health endangering dust.

Turn off all controls before unplugging.

Machine can cause a fire when operating near flammable vapors or materials. Do not operate this machine near flammable fluids, dust or vapors.

This machine is suitable for commercial use, for example in hotels, schools, hospitals, factories, shops and offices for more than normal housekeeping purposes.

Maintenance and repairs must be done by qualified personnel.

If foam or liquid comes out of machine, switch off immediately.

## SAVE THESE INSTRUCTIONS

The following symbols are used throughout this guide as indicated in their descriptions:

### HAZARD INTENSITY LEVEL

There are three levels of hazard intensity identified by signal words -WARNING and CAUTION and FOR SAFETY. The level of hazard intensity is determined by the following definitions:

#### **WARNING:**

WARNING - Hazards or unsafe practices which COULD result in severe personal injury or death.

#### **CAUTION:**

CAUTION - Hazards or unsafe practices which could result in minor personal injury or product or property damage.

**FOR SAFETY:** To Identify actions which must be followed for safe operation of equipment.

Report machine damage or faulty operation immediately. Do not use the machine if it is not in proper operating condition. Following is information that signals some potentially dangerous conditions to the operator or the equipment. Read this information carefully. Know when these conditions can exist. Locate all safety devices on the machine. Please take the necessary steps to train the machine operating personnel.

#### **FOR SAFETY:**

**DO NOT OPERATE MACHINE:**

Unless Trained and Authorized.

Unless Operation Guide is Read and understood.

In Flammable or Explosive areas.

In areas with possible falling objects.

#### **WHEN SERVICING MACHINE:**

Avoid moving parts. Do not wear loose clothing; jackets, shirts, or sleeves when working on the machine. Use manufacturer approved replacement parts.

## THIS PRODUCT IS FOR COMMERCIAL USE ONLY.

### ELECTRICAL

In the USA this machine operates on a standard 15 amp 120V, 60 hz, A.C. power circuit. The amp, hertz, and voltage are listed on the data label found on each machine. Using voltages above or below those indicated on the data label will cause serious damage to the motors.

### EXTENSION CORDS

If an extension cord is used, the wire size must be at least one size larger than the power cord on the machine, and must be limited to 50 feet (15.5m) in length.

### GROUNDING INSTRUCTIONS

This appliance must be grounded. If it should malfunction or break down, grounding provides a path of least resistance for electric current to reduce the risk of electric shock. This appliance is equipped with a cord having an equipment-grounding conductor and grounding plug. The plug must be inserted into an appropriate outlet that is properly installed and grounded in accordance with all local codes and ordinances.

### 120 VOLT MODELS

This appliance is for use on a nominal 120-volt circuit, and has a grounded plug that looks like the plug in "Fig. A". A temporary adaptor that looks like the adaptor in "Fig. C" may be used to connect this plug to a 2-pole receptacle as shown in "Fig. B", if a properly grounded outlet is not available. The temporary adaptor should be used only until a properly grounded outlet (Fig. A) can be installed by a qualified electrician. The green colored rigid ear, lug, or wire extending from the adaptor must be connected to a permanent ground such as a properly grounded outlet box cover. Whenever the adaptor is used, it must be held in place by a metal screw.

### **⚠ WARNING:**

Improper connection of the equipment-grounding conductor can result in a risk of electric shock. Check with a qualified electrician or service person if you are in doubt as to whether the outlet is properly grounded. Do not modify the plug provided with the appliance - if it will not fit the outlet, have a proper outlet installed by a qualified electrician.

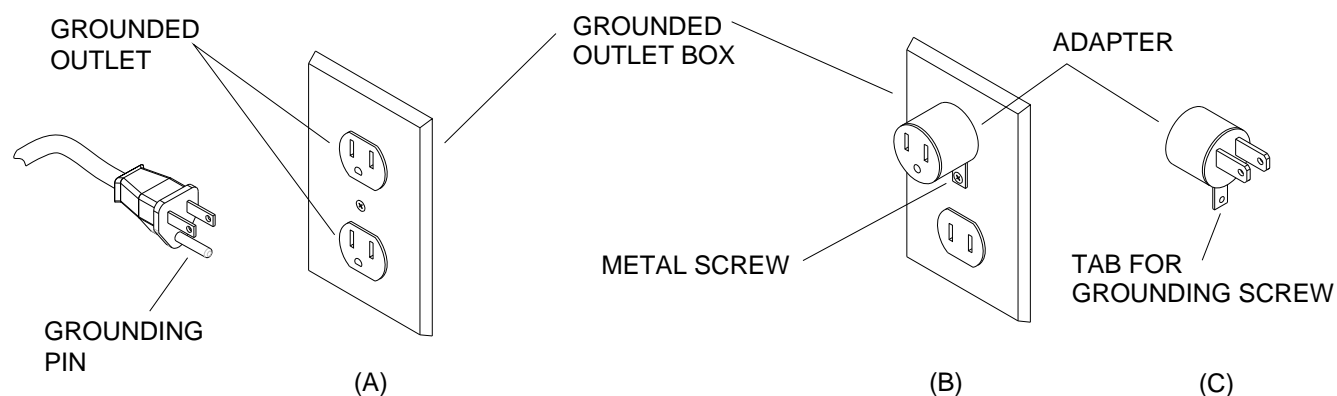

## Safety Label Location

The following **WARNING LABEL(S)** are found on your cleaning unit. These labels point out important Warnings and Cautions which should be followed at all times. Failure to follow warnings and cautions could result in fatality, personal injury to yourself and/or others, or property damage. Follow these instructions carefully! **DO NOT** remove these labels.

*NOTE: If at any time the labels become illegible, promptly replace them.*

WARNING -To reduce the risk of electric shock and fire-Use indoors only.  
Use only detergents intended for cleaning carpet.

AVERTISSEMENT-Pour réduire le risque de choc électrique et d'incendie  
Utiliser à l'intérieur seulement. Utiliser les produits à la nettoyage moquette.

ADVERTENCIA -Para reducir el riesgo de descargas eléctricas y incendios  
Utilice solo en interiores. Utilice solo detergentes adecuada para  
herramienta alfombras.



WARNING LABEL  
PART NUMBER 86220140  
PRV 500895

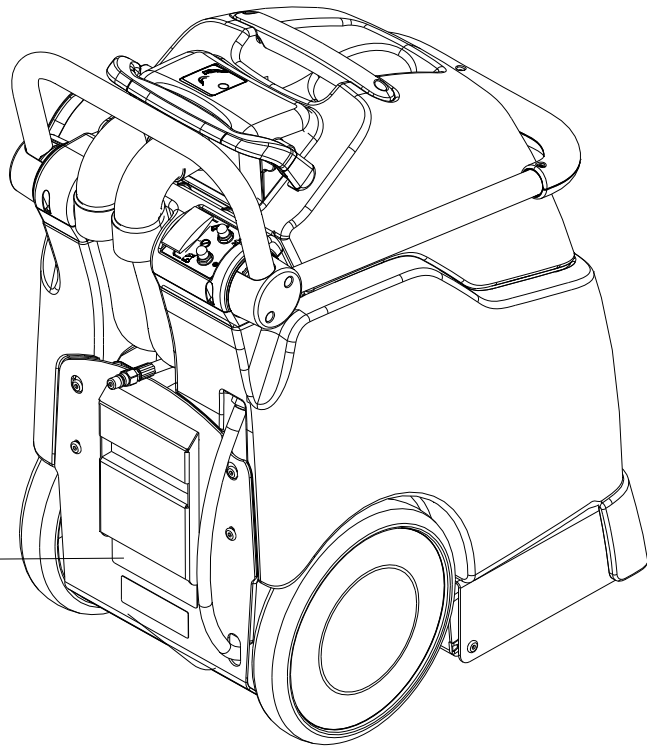

**⚠ WARNING:**

To avoid electric shock use indoors only. To reduce risk of fire, do not use volatile substances. Use only cleaners intended for carpet application.

**Inspection**

Carefully unpack and inspect your extractor for shipping damage. Each unit is operated and thoroughly inspected before shipping, and any damage is the responsibility of the carrier, who should be notified immediately.

**⚠ CAUTION:**

To avoid possible distortion of polyethylene solution/recovery tanks, DO NOT USE WATER TEMPERATURE THAT EXCEEDS 140°F (60° C).

**Chemicals**

Use only the suitable chemicals listed below. Using incompatible chemicals will damage the machine. Damages of this type are not covered under warranty. Carefully read ingredients on manufacturer's label before using any product in this machine.

<b>Suitable Chemicals</b>	<b>Incompatible Chemicals</b>
Alkalis	Aldehydes; Butyls
Defoaming Agents	Carbon Tetrachloride
Detergents	Chlorinated Bleaches
Soaps	Chlorinated Hydrocarbons
Vinegar	Trichlorethylene
Hydroxides	Phenols; Methyls (MEK)
	Perchlorethylene (perc)
	Aromatic Hydrocarbons
	D-Limonene

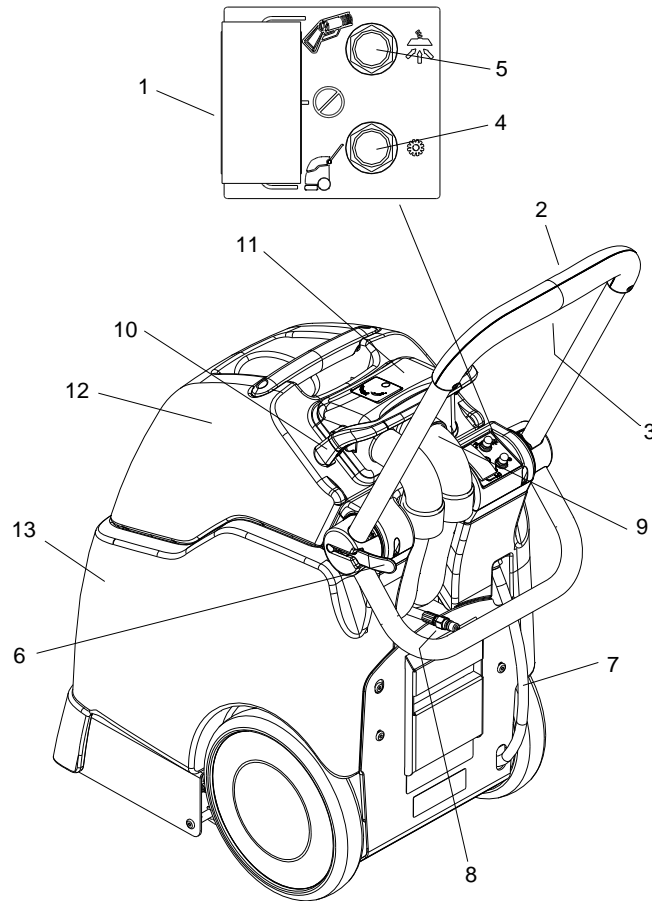

## Controls & Components

### 1. Power and Operation Mode Switch

Turns accessory tool on or machine on.

### 2. Main Handle

### 3. Solution Button

Sprays solution on floor when pressed.

### 4. Brush Motor Circuit Breaker

Protects brush motor from overheating.

### 5. Vac Motor Circuit Breaker

Protects the vac motor from overheating

### 6. Handle Adjustment Lever

Adjusts handle position.

### 7. Solution Tank Drain Hose

### 8. Accessory Tool Connection

Solution connection for accessory tools.

### 9. Accessory Hose Connection

Hose connection for accessory tool.

### 10. Dome Clamp

### 11. Dome

### 12. Recovery Tank

### 13. Solution Tank

## Filling The Solution Tank

1. Release dome clamp.
2. Lift upper recovery tank from machine and set aside.
3. Use a clean bucket, recovery tank or hose to fill solution tank with hot water. The solution tank holds 4 gallons (15.2 liters) of cleaning solution.
4. Add a non-foaming concentrate for use in hot water extractors at the proportions noted on the container.

**NOTE:** *Periodically operate the extractor with only hot water to remove chemical residue in carpet.*

To avoid possible distortion of the polyethylenesolution/recovery tanks, DO NOT USE WATER WITH A TEMPERATURE THAT EXCEEDS 140°F(60°C).

5. Place recovery tank back on machine.
6. Place dome on recovery tank. Make sure dome is seated correctly to ensure proper vacuum seal. Clamp dome securely to recovery tank.

Use only the suitable chemicals listed in the Chemical Section. Using incompatible chemicals will damage the machine. Carefully read ingredients on manufacturer's label before using any product in this machine.

## SPECIAL NOTES:

This appliance is not intended for use by persons (including children) with reduced physical, sensory or mental capabilities, or lack of experience and knowledge, unless they have been given supervision or instruction concerning use of the appliance by a person responsible for their safety. Children should be supervised to ensure that they do not play with the appliance.

The sound pressure level at the operator's ear was measured to be 73.7 dBA. This was a nearfield, broadband measurement taken in a typical industrial environment on a tile floor. This appliance contains no possible source of impact noise. The instantaneous sound pressure level is below 63 Pa.

The weighted root mean square acceleration at the operator's arms was measured to be below 2.5m/s<sup>2</sup>. This was a tri-axial, third-octave-band measurement made during normal operation on a composite tile floor. The measurement and related calculations were made in accordance with ISO 5349-1.

### Operating the Machine

1. Vacuum the carpet and make sure it is cleared of surface debris before cleaning.
2. Plug power cord into a grounded wall outlet.

**NOTE:** *Defeating the grounding pin on the power cord can result in a severe electrical shock.*

3. Turn on the machine by pressing the switch in the normal operation mode.



**NOTE:** *The vacuum and the brush are protected by circuit breakers located on the control panel, to the right of the switch.*

**NOTE:** *If either motor does not respond to being switched on, reset the circuit breakers by pressing them in, and attempt to switch the machine on again.*

**NOTE:** *If solution does not dispense in an even pattern across the width of the machine, the spray jet may be clogged. Tilt the machine back, check for debris and clean surface of jet.*

**NOTE:** *Do not use pins, wire, etc. to clean spray jet nozzle as this will deform the jet and destroy the spray pattern.*

4. While operating machine, check for excessive foam buildup in the recovery tank. If excessive foam is present, add a defoamer solution to recovery tank, or empty tank.
5. Empty recovery tank when approximately 3/4 full. If the recovery tank is overfilled, the water will drain back onto the carpet when the vacuum is switched off.
1. Ventilate area after carpet has been cleaned.

Keep children and pets away and do not walk on carpet until it is dry.

A Windblower™ fan can be used to reduce drying time.

### Operating Machine With Accessory Tools

This extractor is easily adapted for use with Windsor accessory tools: Contact Customer Service for details.

1. Disconnect vacuum hose at dome, insert hose cuff into the dome, ensuring that there is a tight fit. Dome must be clamped to recovery tank.
2. Attach the solution hose from accessory tool to the brass solution fitting on the back of machine.
3. Turn on the switch in the accessory position. The application of cleaning solution is now controlled by the lever on the accessory tool.

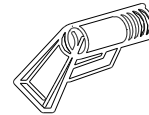

**NOTE:** *The solution pump is not intended to run dry. When using the extractor for vacuum pick-up only. Do not press the solution spray button.*

### **CAUTION:**

**This appliance is not suitable for picking up hazardous dust.**

## Protect From Freezing

If it becomes necessary to store in temperatures that could drop below 40°F, the pumping system, hoses and valves must be protected from freezing with a methyl hydrate window washer antifreeze solution.

**NOTE:** Do not use ethylene glycol or cooling system antifreezes.

1. Add one gallon of window washer antifreeze to the supply tank.
2. Turn on pump switch and spray until the anti-freeze solution fills the solution lines.
3. Drain the leftover antifreeze from the supply tank. Always allow the unit to reach room temperature before filling with hot water or operating.
4. Before operation be sure to flush system completely. Failure to do so after winterizing machine will damage carpet.

## Daily Regular Maintenance

**Before making any adjustments or repairs to the machine, disconnect the power cord from the electrical source.**

1. Empty unused cleaning solution from the solution tank.
2. Inspect and clean filter at solution tank fill port and at the vacuum intake port in the dome.
3. Flush pumping system with 1 to 2 gallons of clean, hot water.
4. Check spray jet for full spray pattern.
5. Empty the recovery tank and rinse with clean water.
6. Check for and remove any lint or debris around brush and vac shoe.
7. Clean float screen and check float valve to make sure it moves freely.

## Periodic Maintenance

1. After every 25 hours of operation, flush a white vinegar solution (ONE quart vinegar to two gallons of water) or anti-browning solution (mixed as directed) through the extractor. This will prevent build-up of alkaline residue in the system.
2. If the spray jet becomes clogged, check for debris and clean surface of jet.

**NOTE:** Do not use pins, wire, etc. to clean spray jet nozzle as this will deform the jet and destroy the spray pattern.

3. Periodically inspect all hoses, electrical cables, filters, gaskets and connections on your machine. Frayed or cracked hoses should be repaired or replaced to eliminate vacuum or solution pressure loss.
4. The electrical cable must be well insulated, if the cable insulation is broken or frayed, repair or replace it immediately. Don't take chances with electrical fire or shock.
5. The filter in the bottom of the solution tank and at the fill port must be clean to allow free flow of cleaning solution. The screen filter on the vacuum intake in the dome must be free of lint buildup to ensure full vacuum strength.
6. The dome gasket must be properly seated and free of damage to create the air seal needed to extract water.

## Maintenance Instructions

### **⚠ WARNING:**

Remove machine power cord from electrical source before making any adjustments or repairs to the machine.

### **⚠ WARNING:**

Only qualified maintenance personnel are to perform repairs.

## Brush Assembly

1. Turn off switch and unplug machine.
2. Position the machine to have access to the bottom. Remove screws (2) at the sides of the machine holding the brush deck pivot axle.
3. Remove screw mounting belt cover and remove belt cover.
4. Loosen the nuts (2) at brush motor and slide motor forward to reduce belt tension. Remove belt.
5. Loosen set screw on brush pulley. Remove pulley.
6. Remove screws (4) mounting brush bearings to frame. Slide bearing off brush axle.
7. Remove brush by lifting drive end out of frame and sliding other end out of bearings mounted to frame.
8. Inspect/replace brush and bearings as required. The brush is equipped with yellow wear indicator bristles. Replace the brush when it wears down to the height of the yellow bristles.
9. Reverse the process to reinstall the brush and bearings. Check belt for proper belt tension.

### **⚠ WARNING:**

Only use the brushes provided with the appliance or those specified in the instruction manual. The use of other brushes may impair safety.

## Spray Jet

**NOTE:** To prevent a clogged jet due to alkali build-up, the spray system should be flushed with 1 to 2 gallons of clean hot water at the end of each day.

1. Turn off switch and unplug machine.
2. Position the machine to have access to the bottom. Remove screws (2) at the sides of the machine holding the brush deck pivot axle.
3. Position the machine to have access to the bottom.
4. Pull off the clip mounting the jet to the frame. Push the jet and hose out of the mounting hole in the frame.
5. Loosen the hose clamp and pull the jet out of the hose.
6. Reverse the process to reinstall the jet. Be sure to have jet rotated correctly before installing clip. Clip tab must face back of machine.

**NOTE:** Do not use pins or wire to remove obstruction if clogged, this may damage jet and alter spray pattern.

## **Brush Motor Removal**

1. Turn off switch and unplug machine.
2. Set the machine in its upright position. Remove the screws (2) in the back metal cover. Rotate the cover down and slide back releasing the tab under the machine from the main frame.
3. Remove the pump box cover. Remove screws (4) at each leg of the cover.
4. To remove brush motor, position the machine to have access to the bottom. Remove screws (2) at the sides of the machine holding the brush deck pivot axle.
5. Remove screw mounting belt cover and remove belt cover.
6. Remove the nuts and washers (2) at brush motor and slide motor forward to reduce belt tension. Remove belt.
7. Remove pulley by loosening set screw and pull off shaft.
8. Unplug the brush motor wires from the rectifier located in the pump mount housing. Also, remove the ground lug from the stud on the main frame by removing the nut on the stud.
9. Reverse the process to reinstall the motor. Align motor pulley with brush pulley. Check belt for proper belt tension.

## **Pump Removal**

1. Turn off switch and unplug machine.
2. Set the machine in its upright position. Remove the screws (2) in the back metal cover. Rotate the cover down and slide back releasing the tab under the machine from the main frame.
3. Remove the pump box cover. Remove screws (4) at each leg of the cover.
4. To remove either pump, loosen the hose clamp and remove the hose from both ends of the pump.
5. Remove screws and washers (4) that mount pump housing.
6. Unscrew the hose fittings from each end of the pump.
7. Flex the pump mounting housing to remove the pump.
8. Remove the screw attaching the ground wire to the pump. Remove the other two wire connectors attached to the pump.
9. Reverse the process to reinstall

## Vacuum Motor Removal

1. Turn off switch and unplug machine.
2. Set the machine in its upright position. Remove the screws (2) in the back metal cover. Rotate the cover down and slide back releasing the tab under the machine from the main frame.
3. Remove the pump box cover. Remove screws (4) at each leg of the cover.
4. Remove vacuum hose, loosen hose clamp and pull hose from bottom of vacuum motor.
5. Unplug wires (2) from main harness located in pump mount housing. Remove ground from stud on main frame.
6. To remove the vacuum motor, remove the screws (2) in the back of the machine that mount the plastic cover to the solution tank.
7. Remove the screws (3) that mount the vacuum motor to the plastic cover. Pull the cover off the vacuum motor.
8. Unscrew the ground wire from the vacuum motor.
9. Reverse the process to reinstall the vacuum motor.

**NOTE:** Make sure the excess wire lengths do not get pinched between the vacuum motor and plastic cover.

**NOTE:** The vac motor is protected by a circuit breaker located in the switch panel. The breaker will only trip under conditions of abuse.

### Vacuum Motor Carbon Brushes

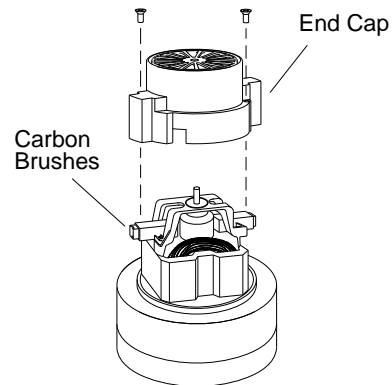

If armature commutator is grooved, extremely pitted or not concentric, the motor will need to be replaced or sent to a qualified service center.

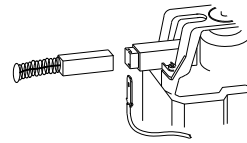

**Important:**  
These brushes wear quicker as the length shortens due to increased heat. Spring inside brush housing will damage motor if brushes are allowed to wear away completely.

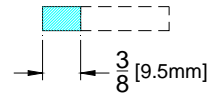

Periodically check the length of the carbon brushes. Replace both carbon brushes when either is less than  $\frac{3}{8}$ " (9.5mm) long.

## Troubleshooting

PROBLEM	CAUSE	SOLUTION
No power, nothing runs.	Is the cord plugged in.	Plug in cord.
	Circuit breaker tripped in building.	Reset breaker.
	Faulty switch.	Call for service.
	Faulty power cord or pigtail.	Call for service.
Vacuum motor will not run.	Vacuum circuit breaker tripped.	Reset breaker.
	Faulty main switch.	Call for service.
	Loose wiring.	Call for service.
	Faulty vac motor.	Call for service.
Vacuum motor runs but suction is poor.	Debris lodged in vac shoe.	Remove debris from vac shoe.
	Dome gasket defective or missing.	Replace as necessary.
	Vacuum hose cracked or hose cuff loose	Replace or repair as necessary.
	Recovery tank full.	Turn off vac motor. Drain and rinserecovery tank.
Poor or no water flow. (carpet is streaky)	Switch to accessory mode.	Turn to deep clean position.
	Jets clogged or missing.	Jets clogged or missing.
	Solution filter clogged.	Drain solution tank and clean solution-filter.
	Faulty solution pump.	Call for service.
Brush does not spin.	Switch in accessory mode.	Turn to deep clean position.
	Brush circuit breaker tripped.	Reset circuit breaker.
	Brush belt broken.	Replace as necessary.
	Faulty brush motor.	Call for service.
Accessory tool fitting difficult to connect	Corrosion on fitting.	Clean with steel wool. Remove and soak in acetic acid (white vinegar). Lubricate lightly with silicone base lubricant.

**Troubleshooting**

<b>PROBLEM</b>	<b>CAUSE</b>	<b>SOLUTION</b>
Worn brush bearings	Squealing or grinding sound in brush housing	Replace bearings.
Carpet not getting clean	Severe soil conditions.	Make several passes at right angles to each other. Use a pre-spray.
Carpet too wet	Worn Spray jet.	Replace spray jet which is producing a fine mist.
Carpet not getting wet	Solution filter screen clogged.	Clean solution filter screen located inside lower tank.
	Spray jet clogged.	Clean or replace spray jet. Do not use a wire to clean jet. DAmaged jet will cause over-saturation.
	Pump not running.	Check for and correct any loose wires. Repair or replace.
	Faulty solution switch.	Replace switch in handle.

# PARTS

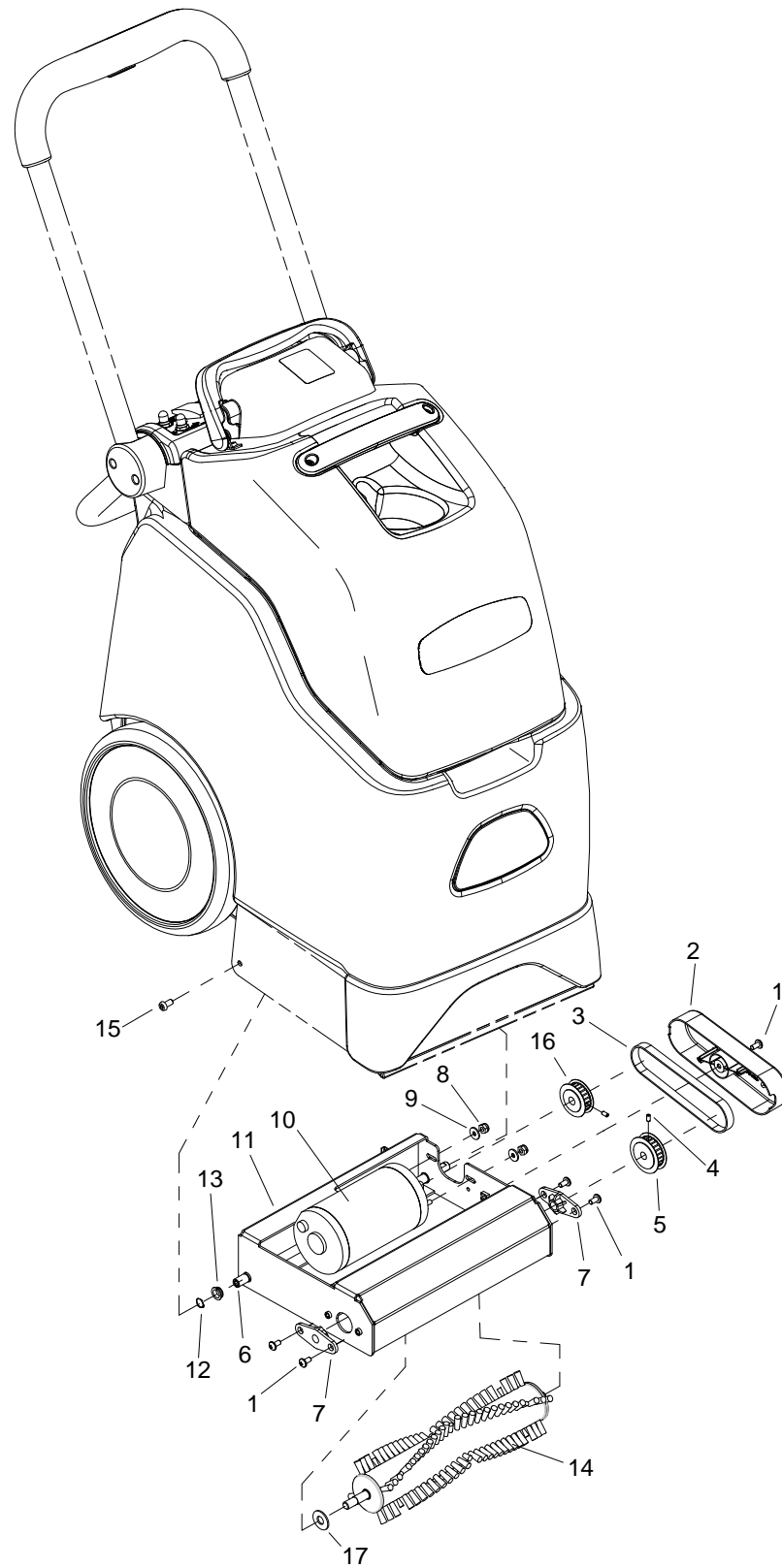

REF	PART NO.	PRV NO.	QTY	DESCRIPTION	SERIAL NO. FROM	NOTES
1	86173020	70916	5	SCR, M5 X 10, PHMS, ISO7045, SS		
2	86217390	270146	1	COVER, PULLEY, BRUSH DECK		
3	86215260	11051	1	BELT, HTD 5MM 69T 9 WIDE		
4	86223780	70896	2	SET SCR, M4 X 6LG, CP BLK		
5	86223300	64115	1	PULLEY, BRUSH		
6	86214970	03124	1	AXLE, PIVOT, BRUSH DECK		
7	86229020	09163	2	BEARING, BRUSH PLASTIC		
8	86005640	57030	2	NUT, 10-32 HEX NYLOCK		
9	86173330	87513	2	WASHER, M5, FLAT, ISO7093, SS		
10A	86247110	53146	1	MOTOR, 115V BRUSH DRIVE		115V ONLY
10B	86306720	-	1	MOTOR ASM, 230V DC PM		230V ONLY
11	86217920	140893	1	BRKT, FLOATING BRUSH, 10 IN		
12	86223490	67468	2	RING, 10MM EXT SNAP, DIN 471		
13	86216430	140912	2	BUSHING, BRUSH PRESSURE		
14	86216040	02506	1	BRUSH, CHEVRON, 10 IN		
15	86173220	70954	2	SCR, M6X12 PHCS, 12.5MM HD,SS		
16	86223350	64125	1	PULLEY, MOTOR		
17	86010680	87030	1	WASHER, 3/8 ID X 3/4 OD NYLON		

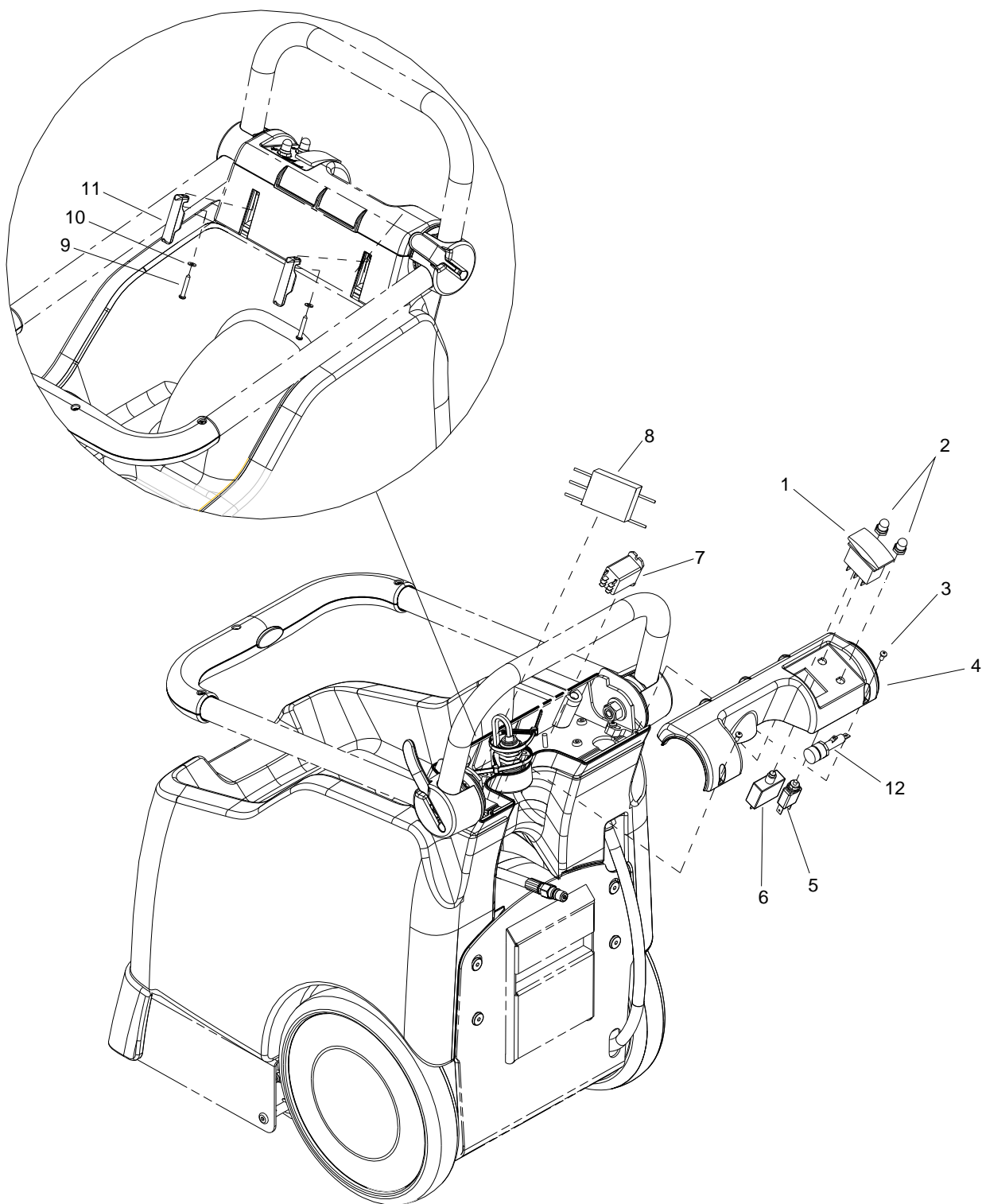

REF	PART NO.	PRV NO.	QTY	DESCRIPTION	SERIAL NO. FROM	NOTES
1	86007200	72162	1	SWITCH, DPDT 3-POSITION ROCKER		
2	86002010	14942	2	BOOT, 3/8 CIRCUIT BREAKER		
3	86173140	70945	2	SCR, KA40X16, PT OVAL, WN1412, PL		
4	86217410	270152	1	COVER, CONTROLS TOP		
5A	86230140	14622	1	BREAKER, 1.5A CIRCUIT		115V ONLY
5B	86001780	14308	1	BREAKER, 0.8A CIRCUIT		230V ONLY
6A	86291460	-	1	BREAKER, 11A VDE CIRCUIT		115V ONLY
6B	86198130	141047	1	BREAKER, 6A VDE CIRCUIT		230V ONLY
7	86223420	67622	1	RELAY, 10A 230VAC SPDT		230V ONLY
8	86302680	-	1	EMI FILTER MAIN		230V ONLY
9	86292300	-	2	SCR, M4X20 SBHCS, BLK EDP		
10	86173350	87515	2	WASHER, M5, FLAT, ISO7089, SS		
11	86216300	140956	2	BUMPER, CONSOLE		

SEE WIRING DIAGRAM FOR WIRE CONNECTIONS.

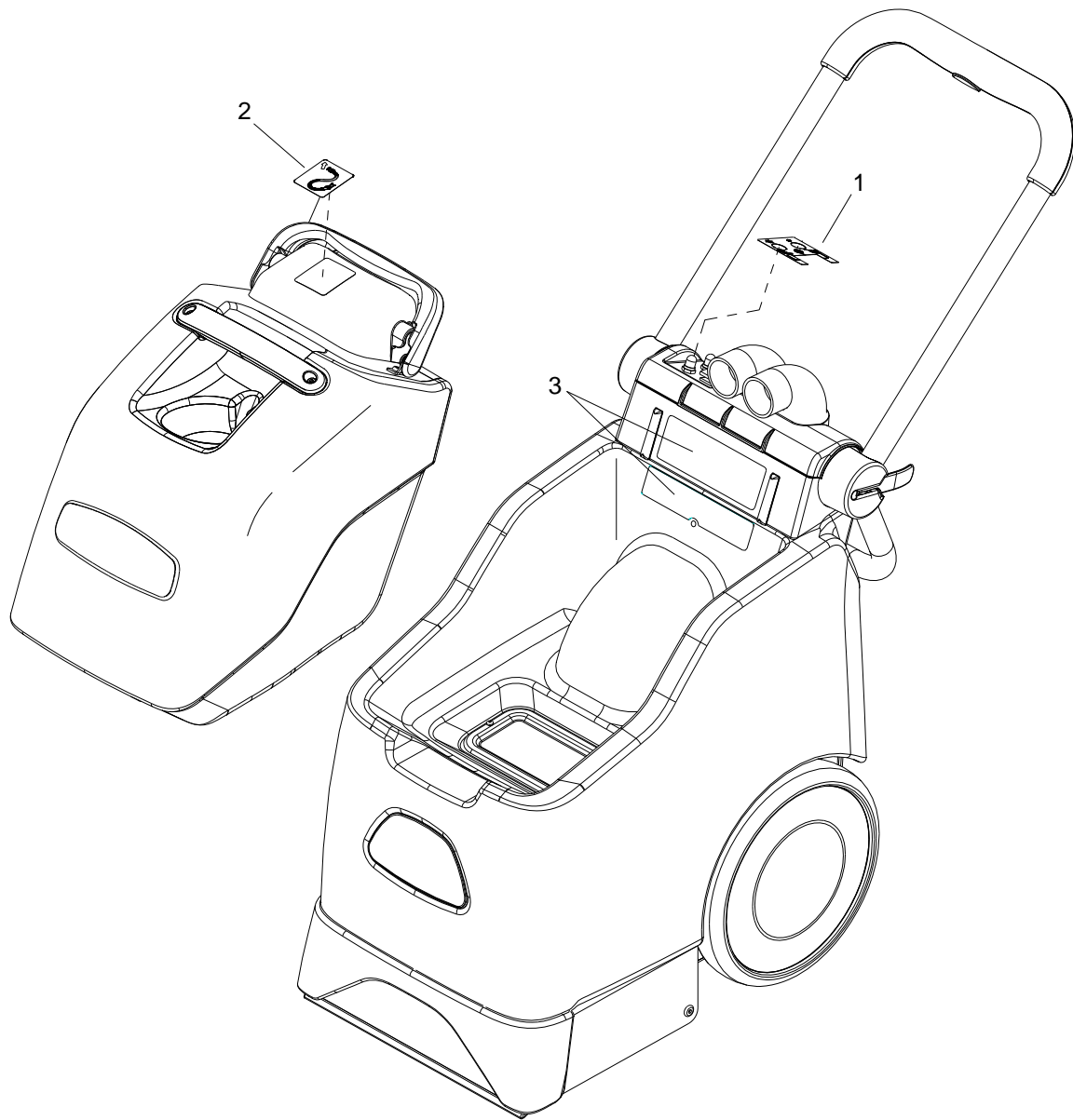

REF	PART NO.	PRV NO.	QTY	DESCRIPTION	SERIAL NO. FROM	NOTES
1	86221090	501128	1	LABEL, CONTROL PANEL		
2	86221470	501208	1	LABEL, DOME ACCESSORY		
3	86013720	-	1	LABEL, MINI EXT.INSTRUCTION		

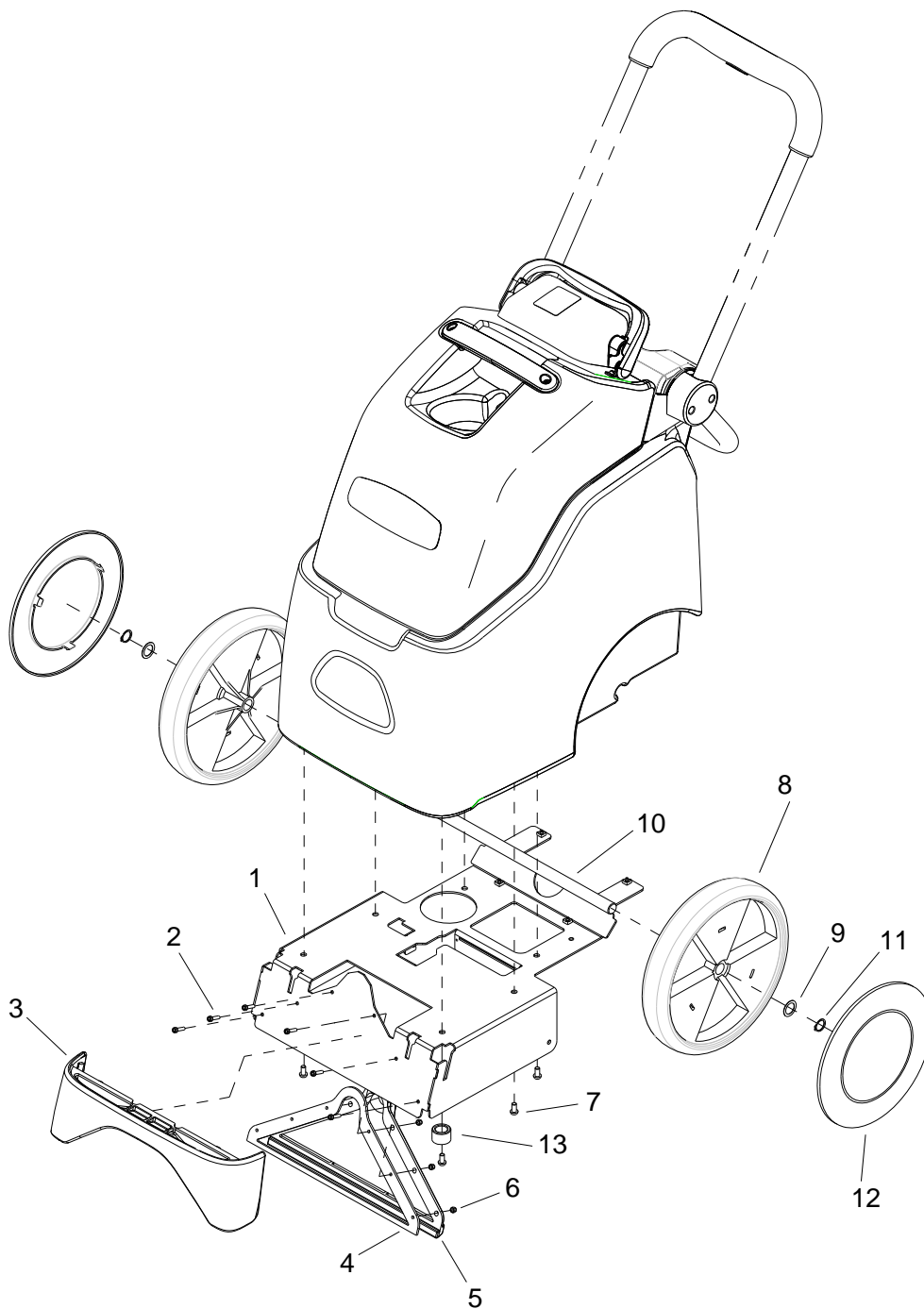

REF	PART NO.	PRV NO.	QTY	DESCRIPTION	SERIAL NO. FROM	NOTES
1	86215830	140897	1	BRKT, BRUSH HOUSING, 10 IN		
2	86173010	70915	6	SCR, M4 X 16, SHCS, ISO4762, SS		
3	86216290	140895	1	BUMPER, EXTRACTOR, FRONT		
4	86218090	35360	1	GASKET, VAC SHOE		
5	86225530	85086	1	VAC SHOE, 12 IN		
6	86172630	57314	6	NUT, M4, LOCK, ISO7040, SS		
7	86173220	70954	6	SCR, M6X12 PHCS, 12.5MM HD, SS		
8	86226050	89279	2	WHEEL, 10IN		
9	86011880	-	2	WASHER, 16.2 X 23 X 0.6MM, PLT		
10	86214980	03125	1	AXLE, WHEELS, 5/8 DIA		
11	86272750	67010	2	RING, 5/8 EXTERNAL SNAP		
12	86219480	41567	2	HUBCAP, 9.75" WHEEL		
13	86291130	-	1	BUMPER, BRUSH DECK		

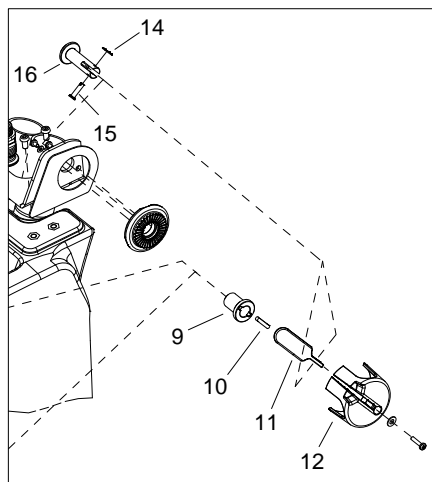
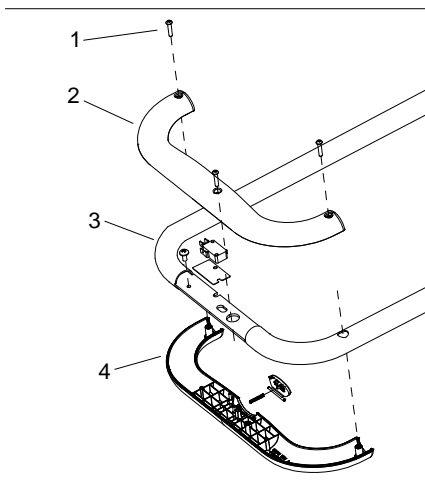
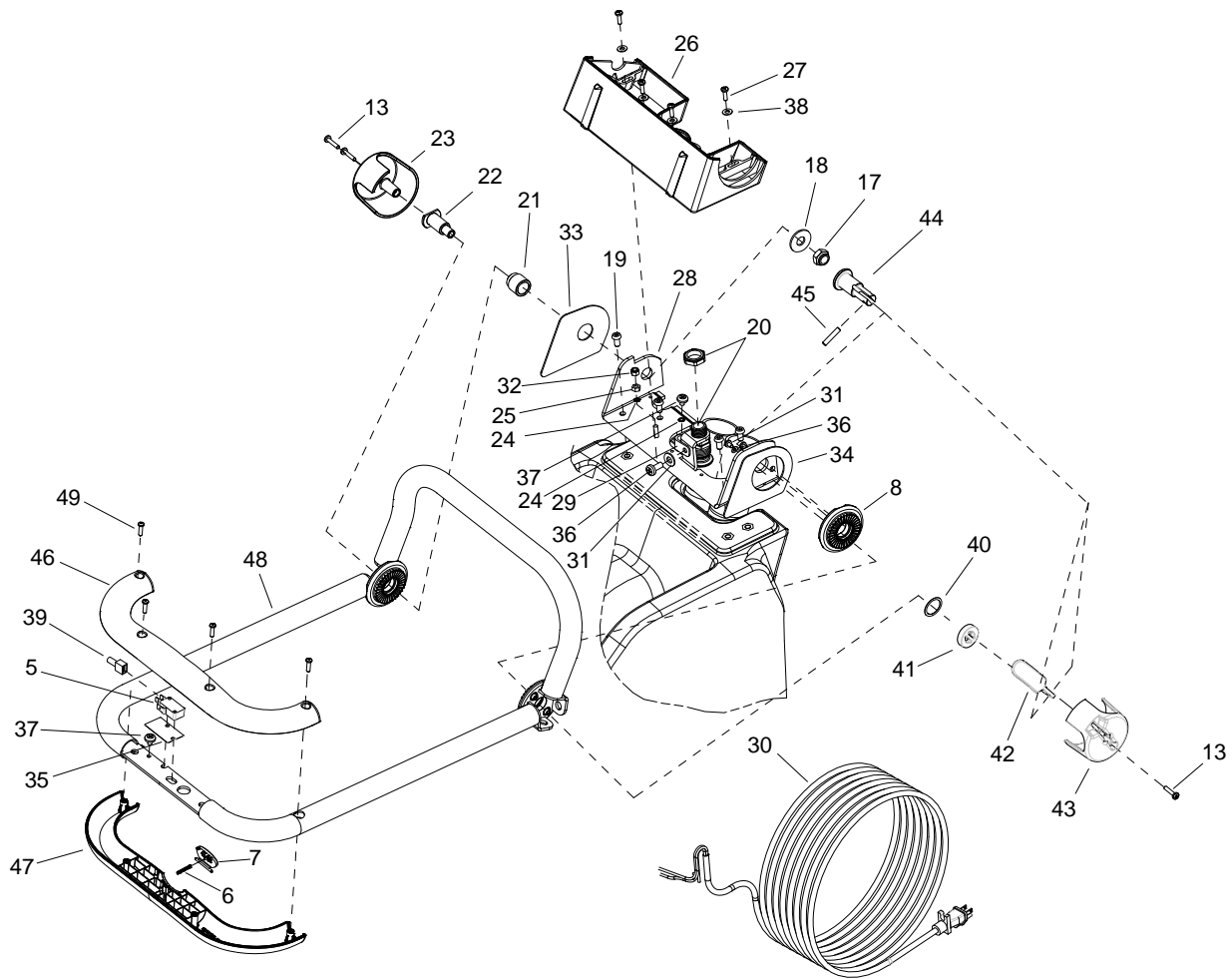

REF	PARTNO.	PRV NO.	QTY	DESCRIPTION	SERIAL NO.FROM	NOTES
1	86012660	-	3	SCR, KA40X25, PT OHCS,WN1452,PL		
2	86218570	38342	1	HANDLE, GRIP BOTTOM		
3	86225910	38343	1	WELDMENT, HANDLE TUBE		
4	86218560	38341	1	HANDLE, GRIP TOP		
5	86225140	72204	1	SWITCH, MICRO		
6	86224650	730392	1	SPRING, LEVER		
7	86216470	140922	1	BUTTON, SPRAY HANDLE		
8	86219460	41553	1	HUB, SPLINE HANDLE		
9	86216440	140934	1	BUSHING, SHAFT HANDLE		
10	86219660	48113	1	KEY, HANDLE CAM, 4X24MM		
11	86221790	51548	1	LEVER CAM HANDLE		
12	86217360	270138	1	COVER, TUBE HUB LEFT		
13	86277600	70882	3	SCR, M4 X 20, PHMS, ISO7045, SET		
14	86008650	80604	1	COTTER, 1/4" RING		
15	86222600	66887	1	PIN, CLEVIS 5MM		
16	86224150	730405	1	SHAFT, HANDLE CAM		
17	86222340	57512	1	NUT, M12, LOCK. ISO 7040, SST		
18	86259430	87485	1	WASHER, M12 FLAT		
19	86173220	70954	4	SCR, M6X12 PHCS, 12.5MM HD, SS		
20	86224930	730012	1	STRAIN RELIEF, 14/3 STRAIGHT		
21	86224460	730406	1	SPACER, SHAFT HANDLE		
22	86224140	730404	1	SHAFT, HANDLE		
23	86217380	270144	1	COVER, TUBE HUB RIGHT		
24	86010640	87016	2	WASHER, #10 LOCK EXT STAR		
25	86270800	57014	1	NUT, 10-32 HEX SS		
26	86217350	270135	1	COVER, CONTROLS, BOTTOM		
27	86172870	70898	4	SCR, M4X14 PHMS, DIN7985 SST		
28	86215520	140921	1	BRACKET, HANDLE AXLE		
29	86233170	20054	1	CLAMP, 3/8 NYLON UL/CSA		
30A	86217140	23732	1	CORD ASM, 14X3 SJTX25'		115V ONLY
30B	86288380	23706	1	CORD ASM, AB EURO		230V ONLY
30C	86217030	23710	1	CORD ASM, AUST AB		230V ONLY
31	86173030	70917	3	SCR, M4 X 6, PHMS, ISO7045, PL		
32	86005640	57030	1	NUT, 10-32 HEX NYLOCK		
33	86218230	35376	1	GASKET, CONTROL BOX RIGHT		
34	86218220	35375	1	GASKET, CONTROL BOX LEFT		
35	86013730	-	1	SHEILD, MICROSWITCH		
36	86173320	87510	3	WASHER, FLAT M4 DIN125 SST		
37	86006770	70323	2	SCR, 10-32 X 1/4 PH PLTD		
38	86288680	87230	4	WASHER, M5 RIVET BACKUP		
39	86266080	76040	1	TERM, 18G .25 FEMALE COUPLER		
40	86296620	-	AS REQ'D	WASHER, 0.2X19.8C25.0MM PLTD	*(2)	
41	86292550	-	1	BUSHING, HANDLE LOCK	*(2)	
42	86296610	-	1	LEVER, CAM HANDLE	*(2)	
43	86296600	-	1	COVER, HUB TUBE LEFT	*(2)	
44	86292560	-	1	SHAFT, HANDLE LOCK	*(2)	
45	86266630	-	1	PIN, DOWEL 5 X 25MM, PLTD	*(2)	
46	86297150	-	1	HANDLE, GRIP TOP	*(1)	
47	86297160	-	1	HANDLE, GRIP BOTTOM	*(1)	
48	86298790	-	1	WELDMENT, HANDLE TUBE	*(1)	
49	86173140	70945	4	SCR, KA40 X 16, PT OHCS, WN1452PL	*(1)	

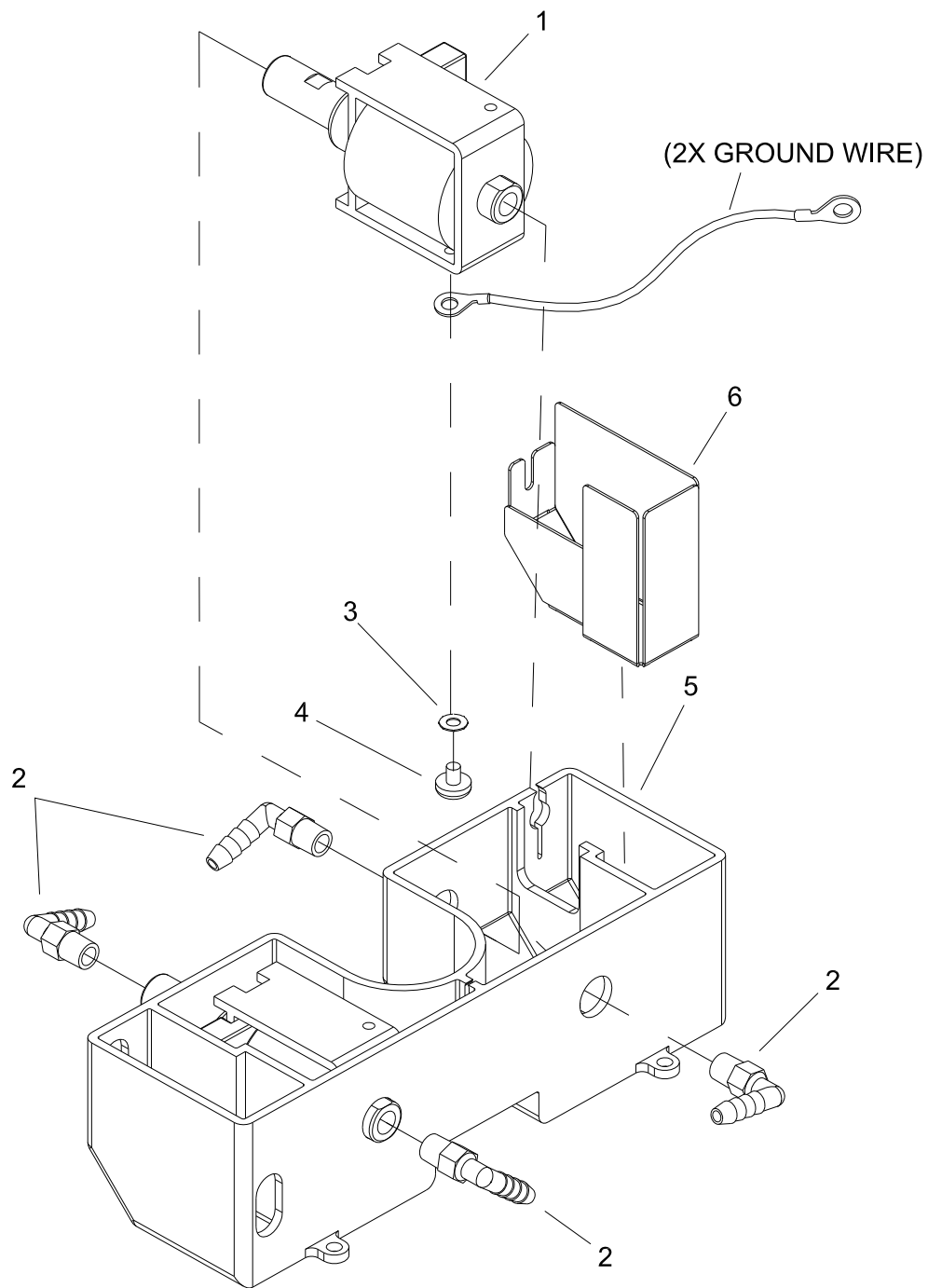

REF	PART NO.	PRV NO.	QTY	DESCRIPTION	SERIAL NO. FROM	NOTES
1A	86201110	250-78	2	PUMP, 110/120 60HZ FLOJET		115V ONLY
1B	86201120	250-78A	2	PUMP, 220/240V 50HZ FLOJET		230V ONLY
2	86240520	40097	4	HOSEBARB, 1/8MPT X 1/4 90D		
3	86010640	87016	2	WASHER, #10 LOCK EXT STAR		
4	86006770	70323	2	SCR, 10-32 X 1/4 PHTR PLTD		
5	86215450	140930	1	BOX, PUMP MOUNT		
6	86304750	-	1	SHEILD, PUMP ENCLOSURE	*(1)	

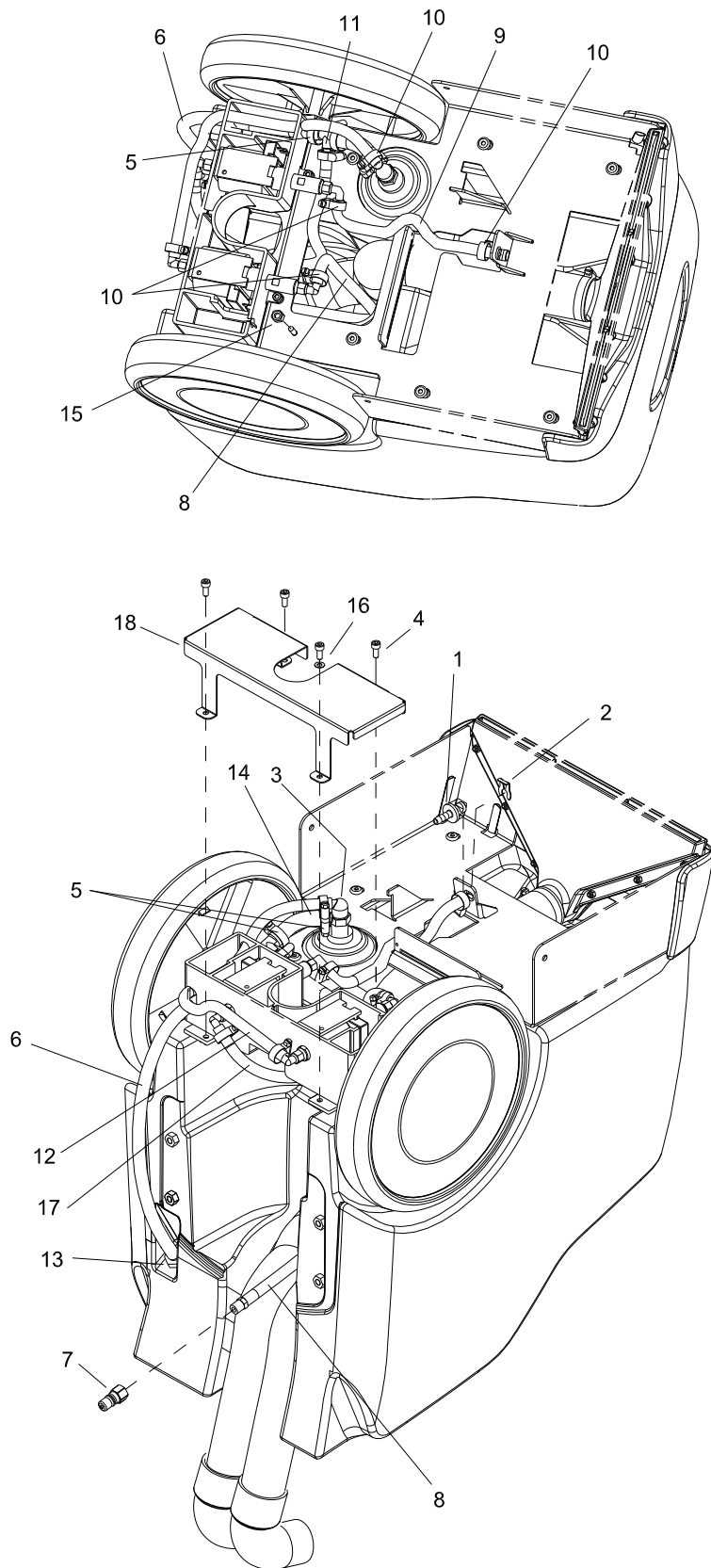

REF	PART NO.	PRV NO.	QTY	DESCRIPTION	SERIAL NO. FROM	NOTES
1	86219580	44106	1	JET, RT ANG, 1/4 BARB		
2	86216810	270131	1	CLIP, SHAFT, 9-12MM		
3	86219200	40114	1	HOSEBARB, 3/8MPT, 2 X 1/4. 1 X 3/8		
4	86172950	70909	4	SCR, M5X12, SHCS, ISO4762, SS		
5	86233150	20042	3	CLAMP, 3/8 HOSE (D-SLOT)		
6	86219090	39728	1	HOSE, 3/8" X 432MM CLEAR		
7	86200820	270-11A	1	NIPPLE, 1/8FPT QD MALE BRASS		
8	86219070	39726	1	HOSE ASM, 6MM X 610MM NYLOBRAID		
9	86219080	39727	1	HOSE, 6MM X 245MM NYLOBRAID		
10	86233090	20016	7	CLAMP, 1/4 ID HOSE		
11	86289330	40062	1	HOSEBARB, TEE 3/8 X 3/8 X 1/4		
12	86219050	39724	1	HOSE, 6MM X 390MM NYLOBRAID		
13	86240430	40083	1	HOSEBARB, 3/8 MPT X 3/8 NYLON		
14	86012680	-	1	HOSE, 3/8ID X 60MM NYLOBRAID		
15	86005640	57030	1	NUT, 10-32 NYLOCK		
16	86010640	87016	1	WASHER, #10 LOCK EXT STAR SS		
17	86219060	39725	1	HOSE, 6MM X 420MM NYLOBRAID		
18	86291670	-	1	COVER, PUMP BOX		

SEE HOSE DIAGRAM FOR HOSE ROUTING.

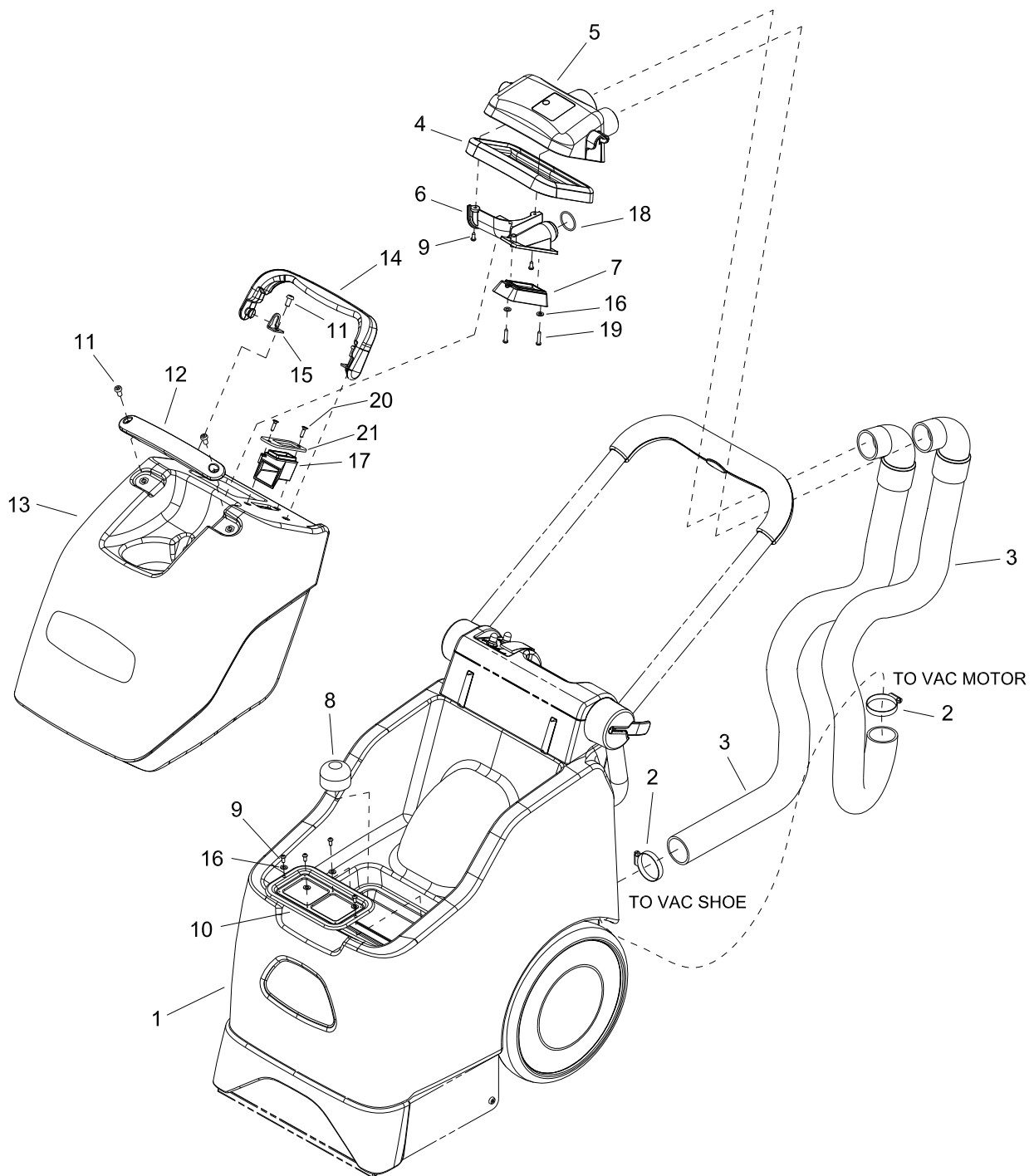

REF	PART NO.	PRV NO.	QTY	DESCRIPTION	SERIAL NO. FROM	NOTES
1	86225240	75471	1	TANK, SOLUTION, EXTRACTOR		
2	86002390	20063	2	CLAMP, 1.75" WORM GEAR X .312		
3	86011910	-	2	HOSE ASM, 1.5X34" VAC W/ELBOW		
4	86291230	-	1	GASKET, DOME, MINI PRO		
5	86217700	28070	1	DOME		
6	86291170	-	1	DOME, PLATE INTERIOR		
7	86291190	-	1	SCREEN, VACUUM INTAKE		
8	86007970	73864	1	STRAINER, 3/8 IN. NPT 60 MESH		
9	86172940	70908	6	SCR, KA40X10,PT OVAL, WN1412,PL		
10	86224960	730373	1	STRAINER, BASKET		
11	86172990	70913	4	SCR, M6X12 BHCS, ISO7380, SS		
12	86218530	38338	1	HANDLE, RECOVERY TANK		
13	86225260	75472	1	TANK, RECOVERY, EXTRACTOR		
14	86216770	22113	1	CLAMP, DOME		
15	86215970	141049	2	BRKT, DOME CLAMP		
16	86173350	87515	4	WASHER, M5, FLAT, ISO7089, SS		
17	86291180	-	1	DUCT, VACUUM INTAKE		
18	86291210	-	1	O-RING, 26MM ID X 2MM THICK		
19	86173000	70914	2	SCR, KA40X20, PT OVAL, WN1412,PL		
20	86291220	-	2	SCR, KA40X16, PT, WN1413, SS		
21	86292450	-	1	GASKET, DUCT		

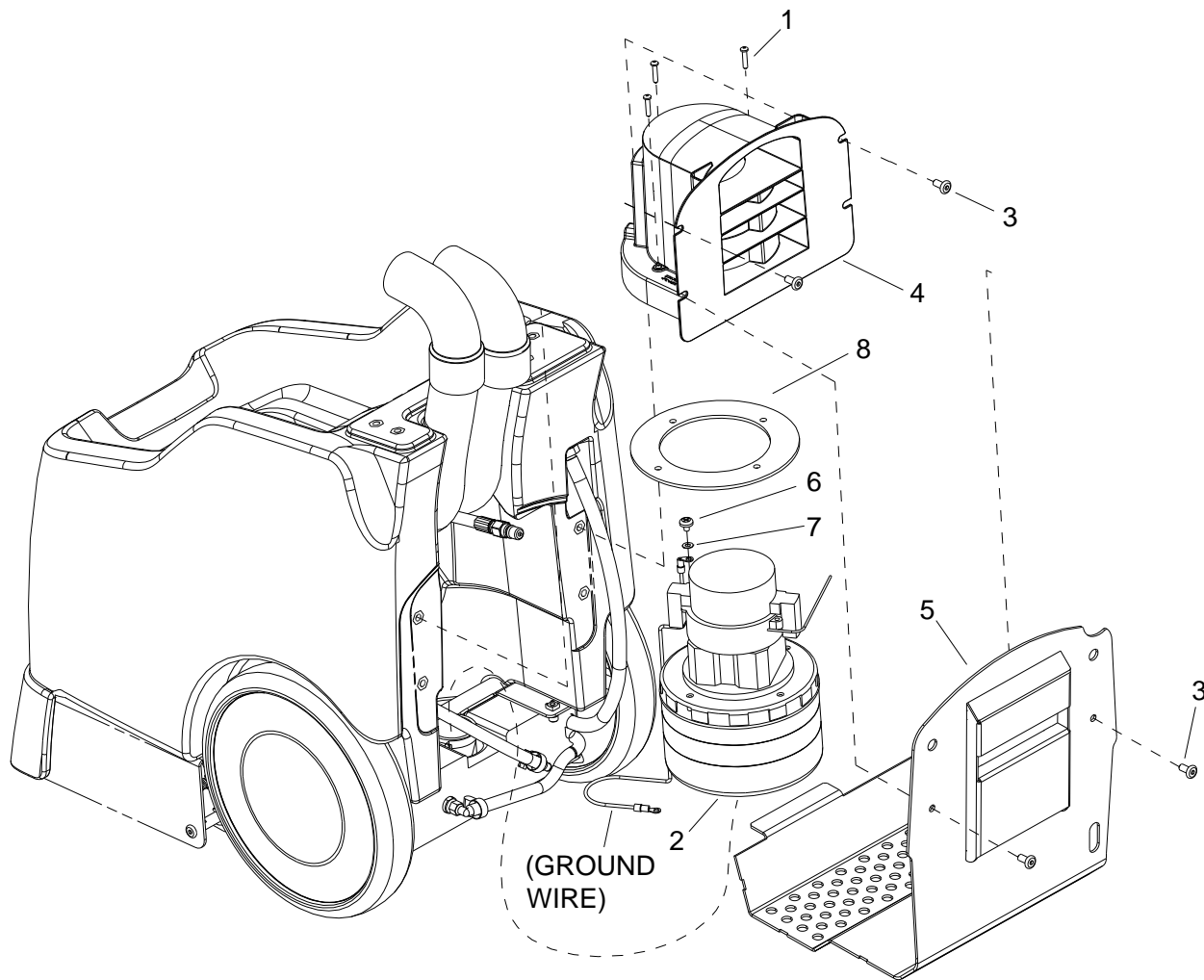

REF	PART NO.	PRV NO.	QTY	DESCRIPTION	SERIAL NO. FROM	NOTES
1	86173000	70914	3	SCR, KA40x20, PT OHS, WN1412, PLTD		
2A	86225480	53272	1	VAC MOTOR, 120V 5.7 3ST W/TUBE		115V ONLY
2B	86308980	-	1	VAC MOTOR ASM, 230V MINIPRO		230V ONLY
3	86173220	70954	4	SCR, M6X12 PHCS, 12.5MM HD, SS		
4	86217420	270703	1	COVER, VAC MOTOR		
5	86217370	270140	1	COVER, LOWER BACK		
6	86006770	70323	1	SCR, 10-32 X 1/4 PHTR PLTD		
7	86010640	87016	1	WASHER, #10 LOCK EXT STAR		
8	86291680	-	1	GASKET, VAC MOTOR		

# Wiring Diagram-Control Panel 115V

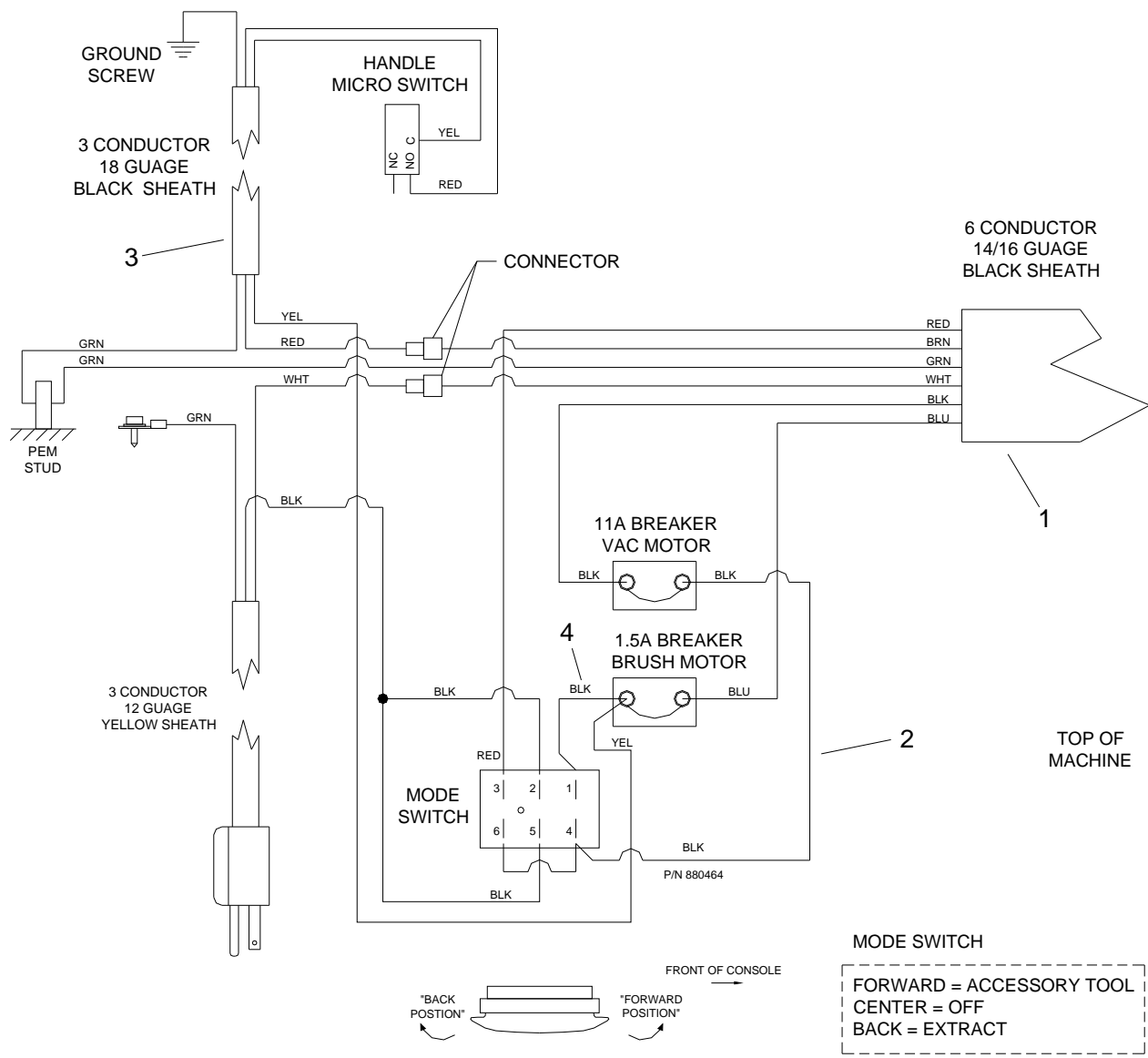

REF	PARTNO.	PRV NO.	QTY	DESCRIPTION	SERIAL NO.FROM	NOTES
1	86218840	41573	1	HARNESS, MAIN		
2	86226230	880464	1	WIRE ASM, CONTROL PANEL JUMPER		
3	86218830	41572	1	HARNESS, HANDLE		
4	86226250	880466	1	WIRE, 14" BLACK/14 76010		

# Wiring Diagram-Vacuum, Brush Motor & Pump115V

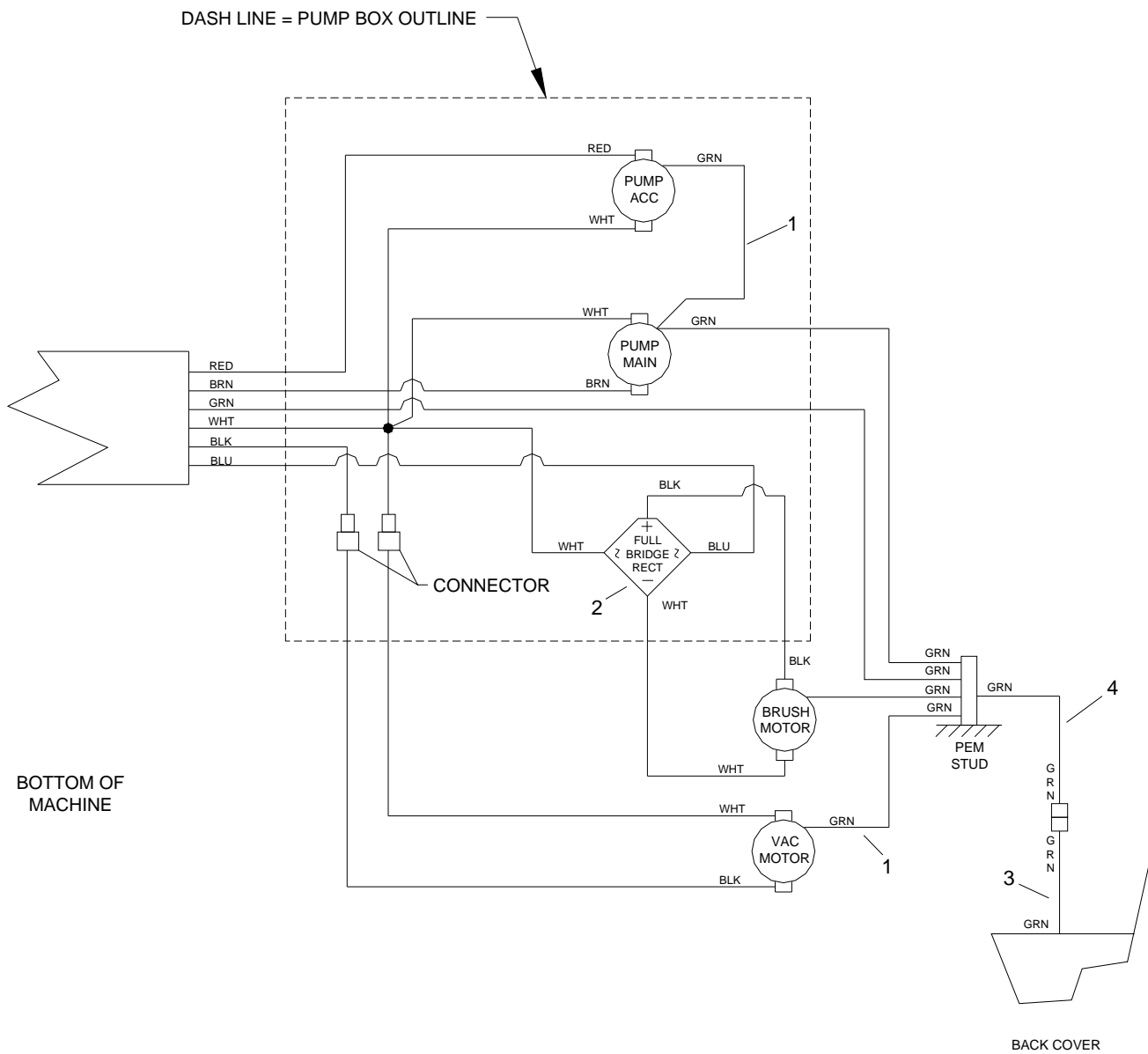

<b>REF</b>	<b>PART NO.</b>	<b>PRV NO.</b>	<b>QTY</b>	<b>DESCRIPTION</b>	<b>SERIAL NO. FROM</b>	<b>NOTES</b>
1	86226250	88884	3	WIRE, 14" GRN/14 76008 X 76008		
2	86223460	67499	1	RECTIFIER, 50A 1000V BRIDGE		
3	86303670	-	1	WIRE ASM, 18 GA GRN 76008/76040		
4	86303680	-	1	WIRE ASM, 18 GA GRN 76008/76042		

# Wiring Diagram-Control Panel 230V

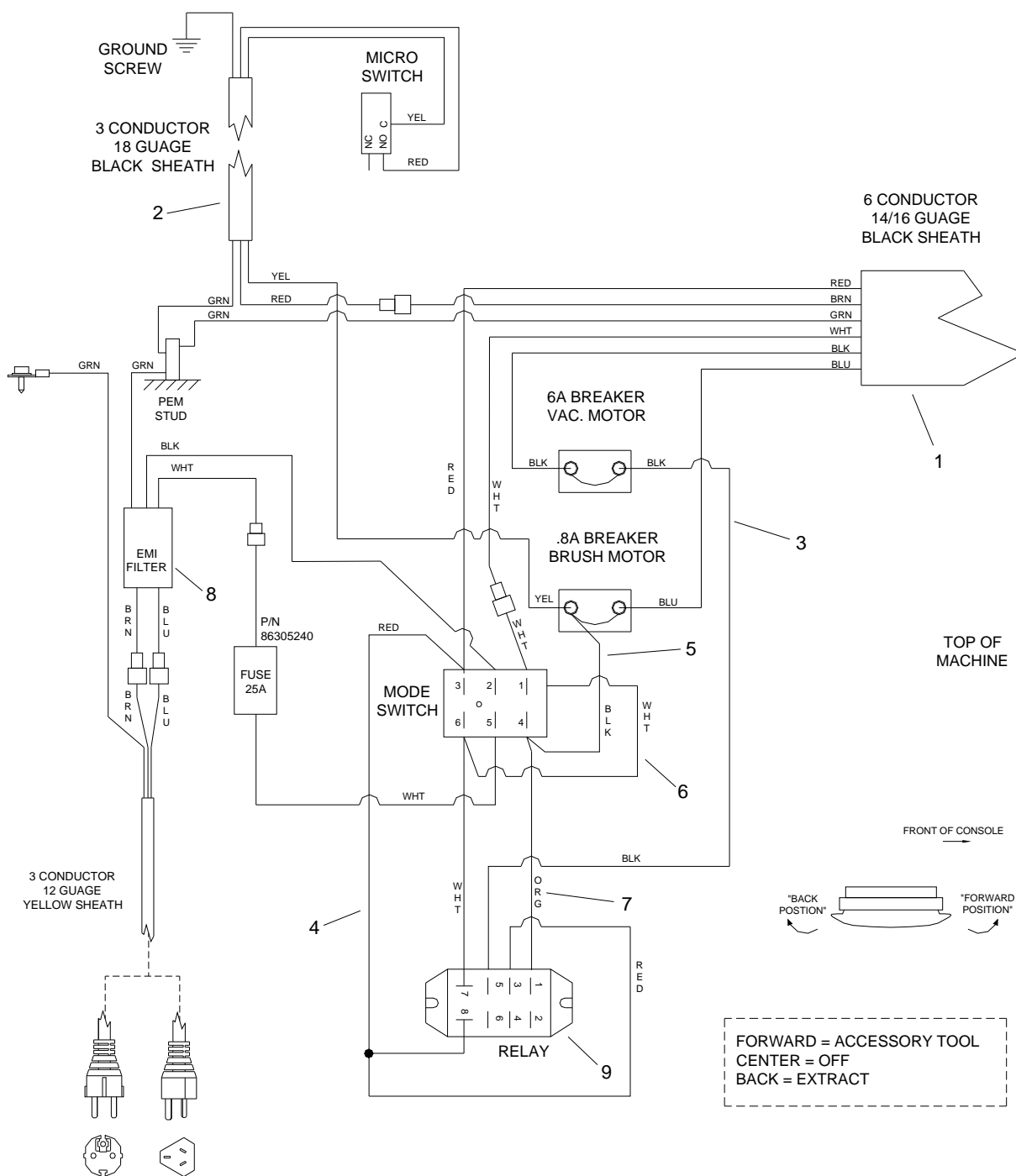

REF	PART NO.	PRV NO.	QTY	DESCRIPTION	SERIAL NO. FROM	NOTES
1	86218840	41573	1	HARNESS, MAIN		
2	86218830	41572	1	HARNESS, HANDLE		
3	86012400	-	1	WIRE ASM, 18GA 4" BLK		
4	86012420	-	1	WIRE ASM, 18GA RED		
5	86226250	880466	1	WIRE, 14" BLACK/14 76010		
6	86012430	-	1	WIRE ASM, 18GA WHT		
7	86012410	-	1	WIRE ASM, 18GA 4" ORG		
8	86302680	-	1	ASM, FILTER EMI MAIN		
9	86223420	67622	1	RELAY, 10A 230VAC SPDT		

# Wiring Diagram-Vacuum, Brush Motor & Pump 230V

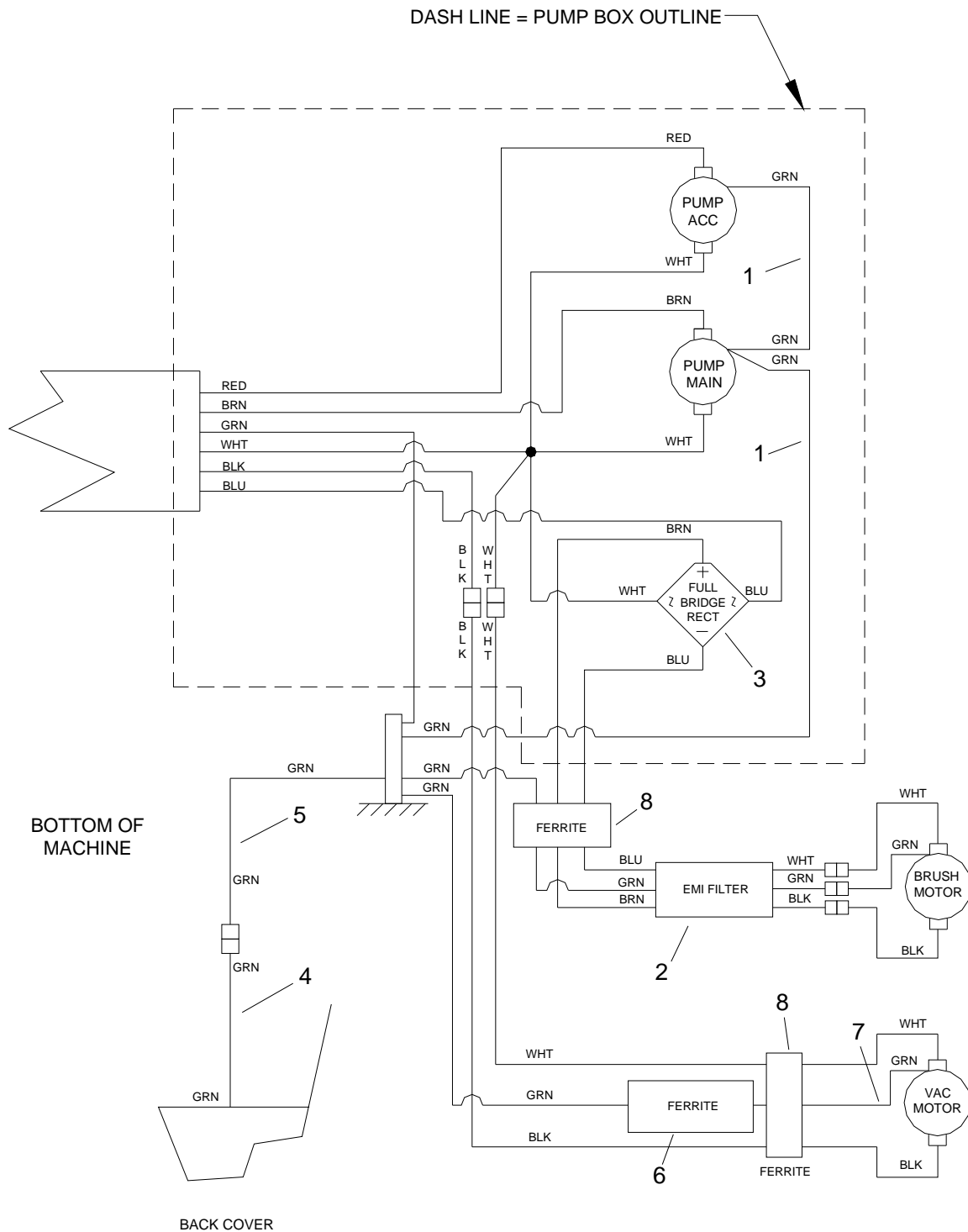

<b>REF</b>	<b>PART NO.</b>	<b>PRV NO.</b>	<b>QTY</b>	<b>DESCRIPTION</b>	<b>SERIAL NO. FROM</b>	<b>NOTES</b>
1	86226310	88884	2	WIRE, 14" GRN/18 76008 X 76008		
2	86308960	-	1	ASM, FILTER EMI BRUSH		
3	86223390	67488	1	RECTIFIER, 50A 600V BRIDGE		
4	86303680	-	1	WIRE ASM, 18 GA GRN 76008/76042		
5	86303670	-	1	WIRE ASM, 18 GA GRN 76008/76040		
6	86302670	-	1	FERRITE, AXIAL LCR 3.007.1943		
7	86309300	-	1	WIRE, 30.5" GRN/18 76008 X 76008		
8	86311030	-	2	FERRITE, WURTH 74270115		

# Hose Diagram

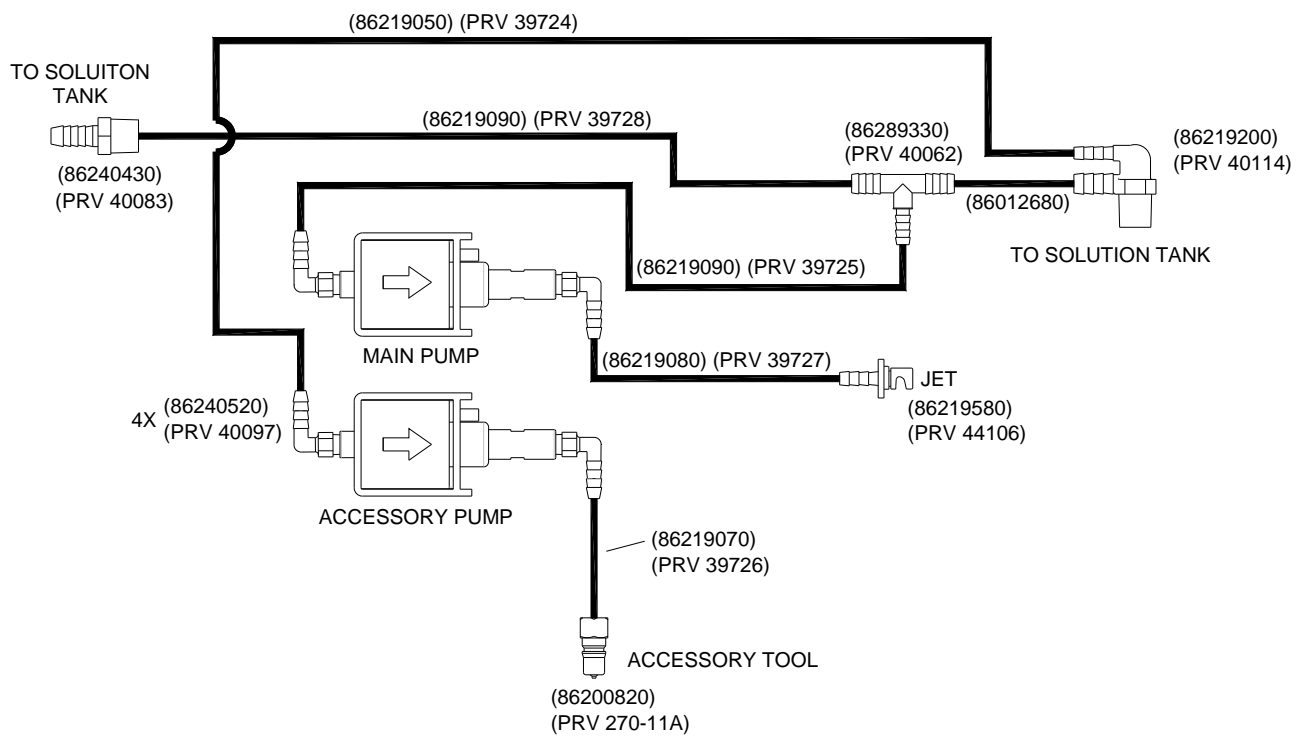

PART NO.	PRV NO.	DESCRIPTION	SERIAL NO. FROM	NOTES
86216430	140912	BUSHING, BRUSH PRESSURE		
86229010	09163	BEARING, BRUSH		
86216040	02506	BRUSH, CHEVRON, 10 IN		
86223350	64125	PULLEY, MOTOR		
86223300	64115	PULLEY, BRUSH		
86215260	11051	BELT, HTD 5MM 69T 9 WIDE		
86247110	53146	MOTOR, 115V BRUSH DRIVE		115V ONLY
86306720	-	MOTOR, 230V DC PM		230V ONLY
86217390	270146	COVER, BELT GUARD		
86218090	35360	GASKET, VAC SHOE		
86219580	44106	JET, RT ANG, 1/4 BARB		
86201110	250-78	PUMP, 110/120 60HZ FLOJET		115V ONLY
86201120	250-78A	PUMP, 220/240V 50HZ FLOJET		230V ONLY
86224960	730373	STRAINER, RECT, 80 MESH SS		
86225480	53272	VAC MOTOR, 120V 5.7 3ST W/TUBE		115V ONLY
86308980	-	VAC MOTOR ASM, MINIPRO 230V		230V ONLY
86135320	140687	BRUSH SET, 120V VAC		115V ONLY
86135330	140688	BRUSH SET, 230V VAC MTR		230V ONLY
86291230	-	GASKET, DOME		
86291190	-	SCREEN, DOME VAC INTAKE		
86291460	-	BREAKER, 11A VDE CIRCUIT		115V ONLY
86230140	14622	BREAKER, 1.5A CIRCUIT		115V ONLY
86215720	141047	BREAKER, 6A VDE CIRCUIT		230V ONLY
86001780	14308	BREAKER, 0.8A CIRCUIT		230V ONLY
86002010	14942	BOOT, 3/8 CIRCUIT BREAKER		
86007200	72162	SWITCH, DPDT3-POSITION ROCKER		

## Accessories

PART NO.	PRV NO.	DESCRIPTION
86218790	HTO	HANDTOOL W/1/8 FEM QD (INCLUDES HOSE ASM)
86290360		HANDTOOL KIT (INCLUDES HOSE ASM AND CARRY BAG)

---

*Serial Numbers*

<b>REF. NO</b>	<b>MODEL: SERIAL #</b>
<b>1</b>	MPRO, MPROEU, MPROGB, MPROAU:1008039000126
<b>2</b>	MPRO, MPROEU, MPROGB, MPROAU:1008039000001

